

**ACL**

**ACL 5500 COMBUSTION SAFETY CONTROL**

**Manufacturing Inc.**

# **INSTALLATION MANUAL**

## **FOR**

# **ACL 5500 COMBUSTION SAFETY CONTROLLER**



## **WARNING**

**This manual must be read in its entirety before installation of this controller. Installation must be performed by a qualified technician and must adhere to the standards set by the local regulatory authorities.**

**ACL is not responsible for the misuse or incorrect application of this product.**

# ACL 5500 COMBUSTION SAFETY CONTROL



## ACL 5500 PROVIDES

- SINGLE & THREE TRIALS FOR IGNITION
- FLAME MONITORING
- INDICATION OF: PILOT ON, POWER ON, & MAIN ON
- FIRST OUT ANNUNCIATION & SHUTDOWN FOR:

- |                   |                   |                  |
|-------------------|-------------------|------------------|
| •POWER FAIL       | •FLAME FAIL       | •REMOTE SHUTDOWN |
| •HI PRESSURE      | •LOW PRESSURE     | •LOW LEVEL       |
| •HIGH TEMPERATURE | •PROOF OF CLOSURE | •AUXILLARY 1     |

- REMOTE STOP AND START CAPABILITIES
- SINGLE OR DUAL BURNER CAPABILITIES
- PRE-PROGRAMMED LOGIC  
(NO PROGRAMMING NECESSARY)



- Power supply 12/24 VDC, 120/240 VAC 50/60 Hz, low power consumption, suitable for solar applications
- Flame out response time of 0.8 seconds
- CSA approved for Class I, Div 2 location
- CSA approved C22.2 No 199-M89. Combustion safety controls and solid-state Ignitors for Gas & Oil burning Equipment
- CSA B149.3 - 10 compatible
- Type 4x enclosure, corrosive resistant and weatherproof

# ACL 5500 COMBUSTION SAFETY CONTROL

**APPLICATION** The ACL 5500 Combustion Safety controller is designed to ignite and prove a continuous pilot while monitoring and annunciating multiple heater shutdowns for all types of gas fired heaters and industrial sized burner applications.

**THEORY OF OPERATION** The ACL 5500 utilizes a single ignitor/flame rod to provide both flame acknowledgment and ignition at the pilot tip. When the ACL 5500 starts its ignition sequence, fuel gas travels to the pilot tip where the ignitor/flame rod is located and sparking. Once the gas is lit, the flame becomes a current path for flame acknowledgment and the unit stops sparking. After the pilot has been proven for 20 seconds (factory set) the ACL 5500 will allow gas to the main burner.

If the pilot flame is extinguished, the current path is broken and the ignitor/flame rod starts sparking within 1 second to attempt to re-light the pilot. The main is shut off during this re-light period. If a flame is not established within the 5 second sparking period, the controller will immediately drop the output to solenoid #1 pilot gas valve. The controller will attempt to light 2 more times with 15 seconds between each trial when equipped with three trial module. If the flame is still not lighting, the flame fail will then be displayed on the annunciation panel.

If any of the shutdowns are tripped, the controller will not attempt any re-light, solenoid outputs will de-energize immediately and that specific shutdown will then be indicated on the annunciation panel. The shutdown must be cleared before the controller will allow an ignition cycle.

In an application where the ACL 5500 is used to ignite and monitor two burners, ignition will occur at both pilots simultaneously when a start is initiated. If a flame is not established at both pilots during the 5 second trial for ignition the solenoid #1 outputs will drop out closing both pilot valves and a flame fail will be indicated on the annunciator panel (slow flash for pilot #1 and quick flash for pilot #2). If both pilots have been proven for a period of 20 seconds solenoid #2 outputs will be energized allowing the main burner valves to open. During normal operation should either pilot be extinguished there will be a 5 second trial for re-ignition at that pilot, and the main solenoid outputs will be shut off during the trial for ignition period. If a flame is not re-established during the 5 second period the remaining pilot solenoid output will be de-energized closing the pilot gas outputs immediately and will not attempt any re-light. The specific shutdown will then be indicated on the front annunciator panel. The shutdown must be cleared before the controller will allow an ignition cycle.

# ACL 5500 SAFETY COMBUSTION CONTROL

## INSTALLATION

- ACL 5500 controller c/w mounting hardware
- ACL M-50A pilot mixer & nozzle
- 10' ground wire
- 10' high voltage wire complete with connectors
- 6.5' non-metallic flex complete with connectors
- Ignitor/flame rod complete with mounting hardware
- Speed control valve
- 1/2" conduit seal
- Flame current test leads
- Operator's manual

**ACL 5500 COMES  
COMPLETE WITH**

The ACL 5500 can be mounted in a Class I, Div 2 area; usually close to the burner. The 10' of high voltage lead, (longer length not recommended) must be run in the non-metallic flex (provided) or free air. If the high voltage lead is run in the non-metallic flex, a conduit seal (provided) must be installed. Note: Lead length in excess of 10' or use of metal or metallic sheathed conduit may result in a diminished ignitor rod voltage. A ground wire (also supplied) must be connected between the ground lug on the burner assembly and the bonding ground terminal on the main circuit board. **Note: If the controller must be mounted farther away from the burner assembly, the ignition module, which is mounted on the main circuit board, may be mounted in or near the burner housing using the optional, CSA approved, ACL 5000R remote mount kit. Do not coil excess high voltage lead inside controller enclosure. High voltage noise may damage sensitive components.** When the 5500 is used in a dual burner application at least one of the ignition modules must be remotely mounted as the controller housing will not accommodate two ignition modules. (Dual Burner kit needed for dual burner applications)

### **MOUNTING**

The ACL 5500 is available in 12/24 VDC and 120/240 VAC. Voltage requirements must be specified when ordering. The supply voltage of each unit is clearly marked inside the door on the specification label and on the circuit board beside its respective terminal. **Incorrect polarity on 12/24 VDC units may result in damage to circuit board components.** The terminal marked ground is for supply or system ground and the terminal marked bonding ground is strictly for the ground wire to the burner assembly. It is important that a ground wire (supplied) be connected between the bonding ground terminal and the burner assembly to provide an uninterrupted path for the flame acknowledgment current.

### **POWER CONNECTION**

There are four solenoid output terminals on the main circuit board marked pilot solenoid and main solenoid, 2 for burner #1 and 2 for burner #2. The output voltage at these terminals is always the same as the controller supply voltage. The pilot solenoid output connects to the pilot or low fire solenoid and is energized when a start is initiated. Main solenoid, (main burner) energizes only after the pilot or low fire flame has been proven. The time delay between proof of flame and energizing of main output is factory set at 20 seconds. The solenoid outputs are rated at 5A 250V each.

### **SOLENOID OUTPUTS**

# ACL 5500 COMBUSTION SAFETY CONTROL

## S/D INPUTS & ALARM ANNUNCIATION

The shutdown input provides a means of connecting other shutdown devices for High pressure, Low pressure, High temperature, Low level and Axillary 1 where necessary for additional protection. Jumpers are installed at the factory and should only be removed to utilize each individual shutdown. If any of the S/D devices go to a fault condition their contacts will open, de-energizing the solenoid outputs , shutting down fuel to the burner and disabling the re-light sequence. The fault will be annunciated on the front of the controller. Once the fault condition is corrected the system can be restarted by pressing the stop/reset and then the start buttons. **Note: If a restart is attempted without clearing the fault condition the controller will not attempt a re-light. 18 awg wire is recommended for all the shutdowns for ease of wiring. Must be dry contacts.**

## REMOTE S/D (STOP)

The remote S/D function is available when the jumper is removed and a momentary normally closed contact button or remote relay contact (N/C) is utilized. **Note: Must be dry contacts.**

## REMOTE START

The remote start function is available when a momentary normally open contact button or remote relay contact (N/O) is utilized. When contacts close momentarily the unit initiates starting sequence.

## PROOF OF CLOSURE (P.O.C)

This feature allows controller to use valves with proof of closure switches for ensuring main valve is closed before initiating an ignition. When valve switch contacts are in an open state indicating the valve may be open, the controller will not start. The contacts must be closed in order for controller to start. Once start is initiated, the contacts from proof of closure switch can then change state.

## TEMPERATURE CONTROL

The temperature control option is provided to allow the use of a temperature switch to turn the main solenoid output on & off, controlling the main gas valve to the burner. This does not override the shutdown logic of the output. When using this option, the temperature switch must have dry contacts. When not in use, a jumper must be installed as per drawings.

## ALARM STATUS

Alarm status is provided from a set of normally open/normally closed **dry contacts** which change state when a pilot flame is detected. If the pilot goes out due to any of the shutdowns or fails to re-light, the contacts return to normal or alarm state.

**NOTE: A jumper must be placed between terminal numbers 34 and 36 when the ACL 5500 is being used for a single burner application.**

# ACL 5500 SAFETY COMBUSTION CONTROL

<b>SPECIFICATIONS DC</b>				
	<b>ONE BURNER</b>		<b>TWO BURNER</b>	
<b>VOLTAGE</b>	12 VDC	24VDC	12 VDC	24 VDC
<b>CURRENT</b>	0.206A	0.139A	0.292A	0.200A
<b>POWER</b>	2.472W	3.336W	3.504W	4.80W
<b>SOLENOID OUTPUT RATINGS</b>	5 amp 250 V Per Output		5 amp 250 V Per Output	
<b>OPERATING TEMPERATURE</b>	-40 C to 60 C		-40 C to 60 C	
<b>FLAME SENSITIVITY</b>	1 micro amp minimum		1 micro amp minimum	
<b>FLAME FAILURE RESPONSE TIME</b>	0.8 seconds maximum		0.8 seconds maximum	
<b>SPARK RATE</b>	25 sparks per second		25 sparks per second	

<b>SPECIFICATIONS AC</b>				
	<b>ONE BURNER</b>		<b>TWO BURNER</b>	
<b>VOLTAGE</b>	120 VAC	240 VAC	12 VDC	24 VDC
<b>CURRENT</b>	0.306A	0.156A	0.292A	0.200A
<b>POWER</b>	36.72W	37.44W	3.504W	4.80W
<b>FREQUENCY</b>	50/60 HERTZ		50/60 HERTZ	
<b>SOLENOID OUTPUT RATINGS</b>	5 amp 250 V Per Output		5 amp 250 V Per Output	
<b>OPERATING TEMPERATURE</b>	-40 C to 60 C		-40 C to 60 C	
<b>FLAME SENSITIVITY</b>	1 micro amp minimum		1 micro amp minimum	
<b>FLAME FAILURE RESPONSE TIME</b>	0.8 seconds maximum		0.8 seconds maximum	
<b>SPARK RATE</b>	25 sparks per second		25 sparks per second	

# ACL 5500 COMBUSTION SAFETY CONTROL

## ACL 5500 12/24 VDC 1 Burner System

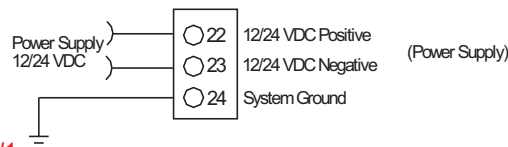
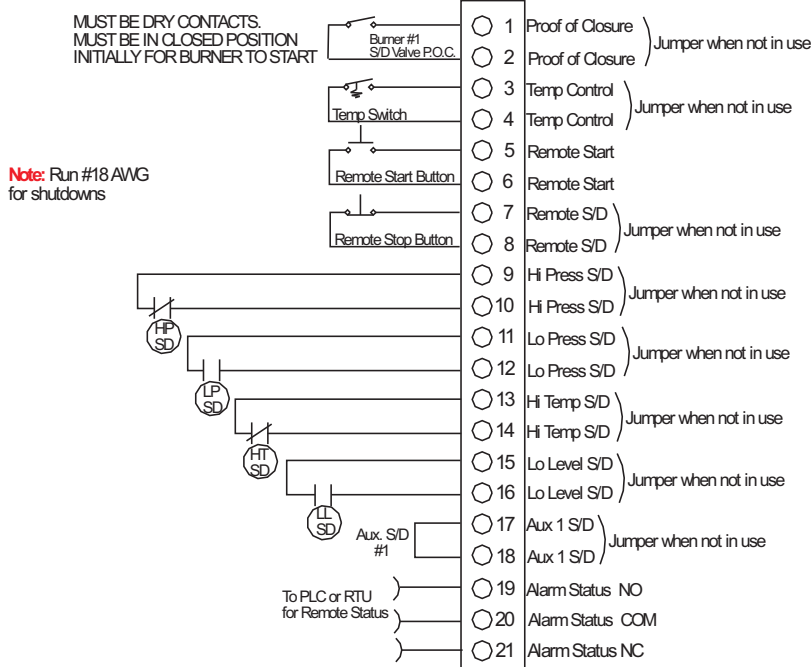

### BURNER #1

### BURNER #2 (Optional)

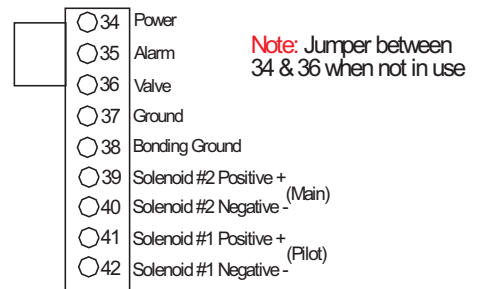
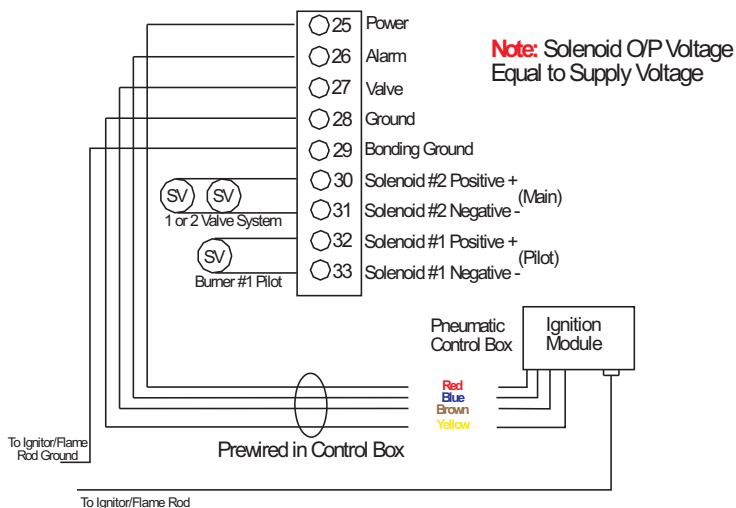

Note: If remote mounting of ignition module is preferred, the ACL 5000R remote mount kit is available upon request

# ACL 5500 SAFETY COMBUSTION CONTROL

## ACL 5500 12/24 VDC 2 Burner System

MUST BE DRY CONTACTS.  
MUST BE IN CLOSED POSITION  
INITIALLY FOR BURNER TO START

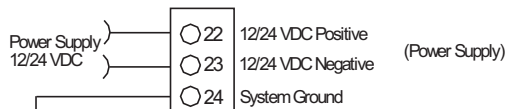
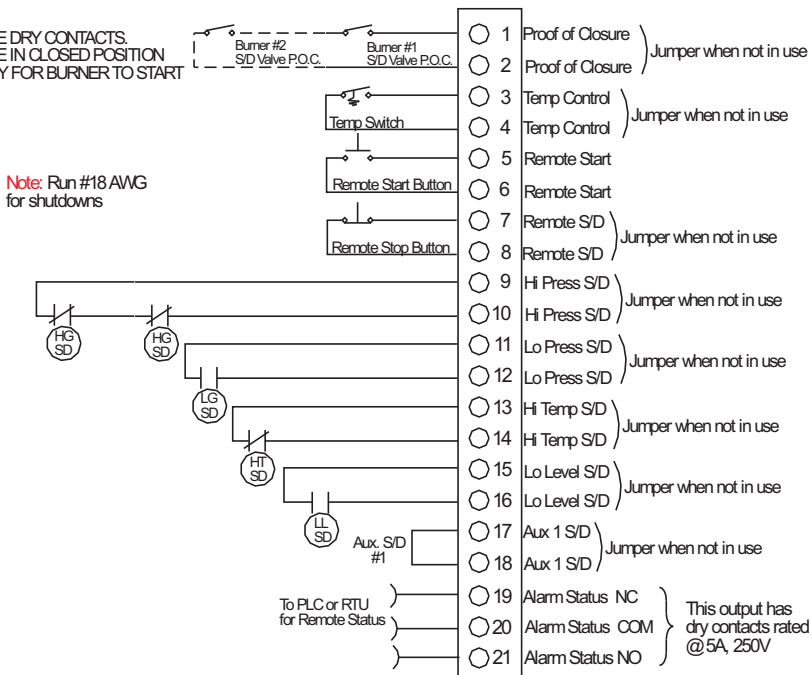

### BURNER #1

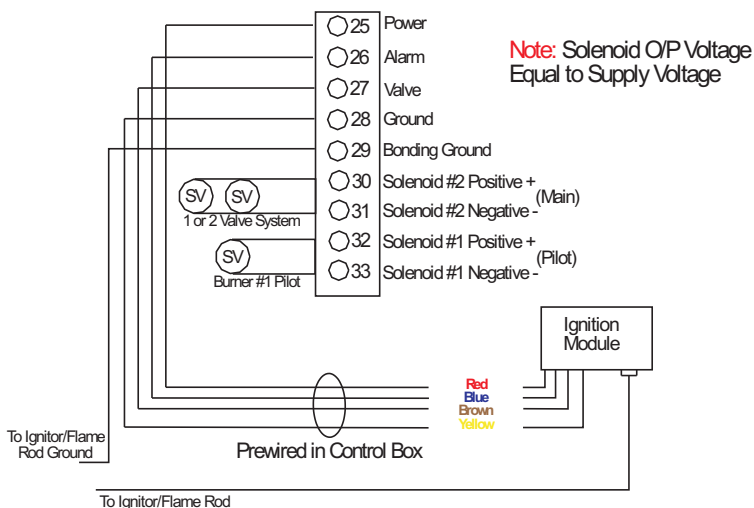

### BURNER #2

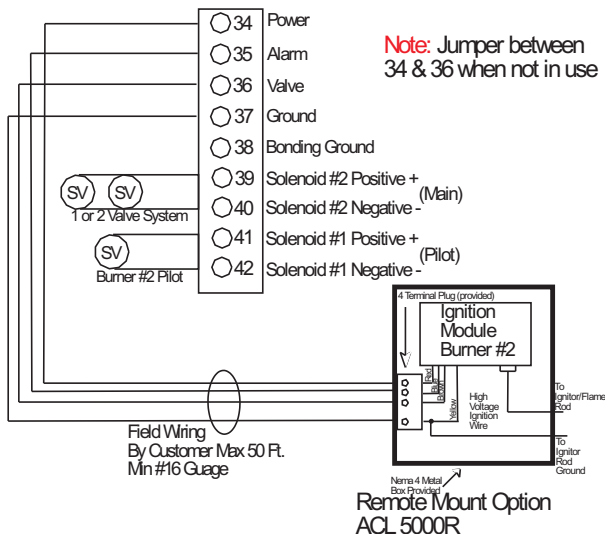

# ACL 5500 COMBUSTION SAFETY CONTROL

## ACL 5500 120/240 VAC 1 Burner System

MUST BE DRY CONTACTS.  
MUST BE IN CLOSED POSITION  
INITIALLY FOR BURNER TO START

**Note:** Run #18 AWG  
for shutdowns

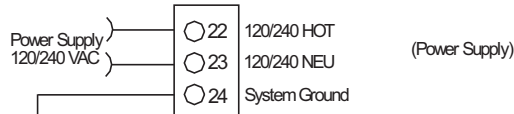
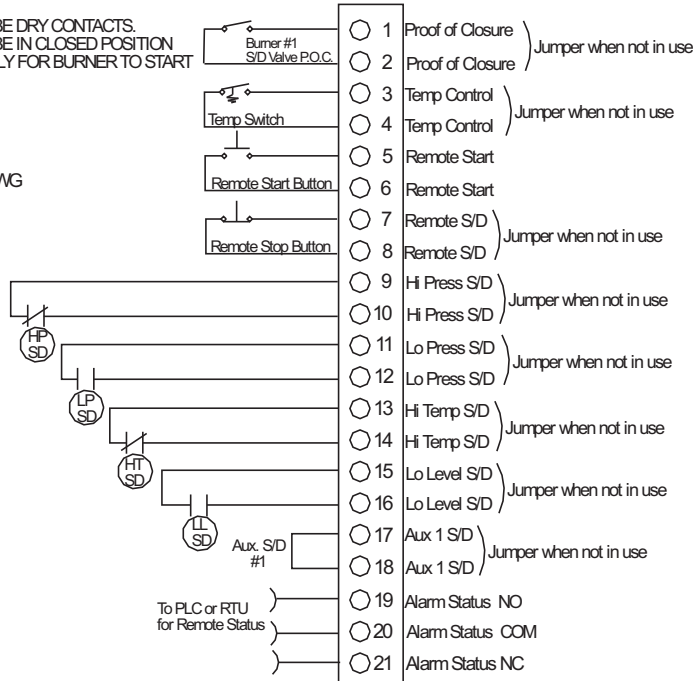

### BURNER #1

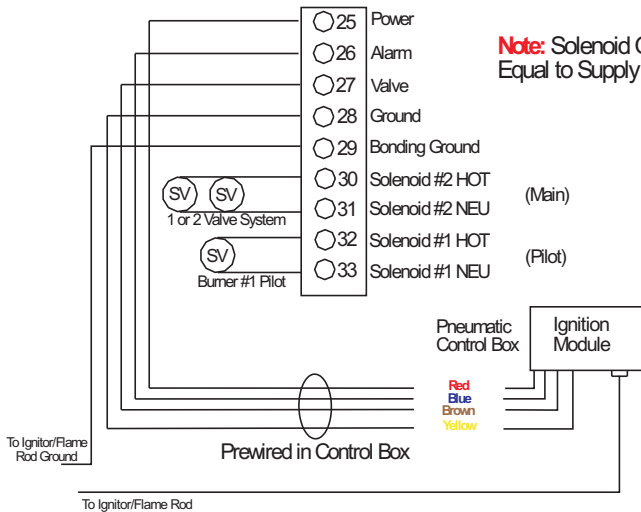

**Note:** Solenoid O/P Voltage  
Equal to Supply Voltage

### BURNER #2 (Optional)

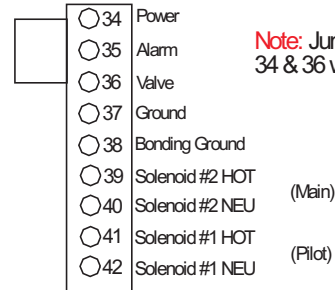

**Note:** Jumper between  
34 & 36 when not in use

**Note:** If remote mounting of ignition  
module is preferred, the ACL 5000R remote  
mount kit is available upon request

# ACL 5500 SAFETY COMBUSTION CONTROL

## ACL 5500 120/240 VAC 2 Burner System

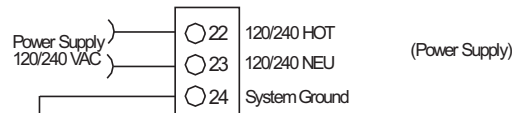
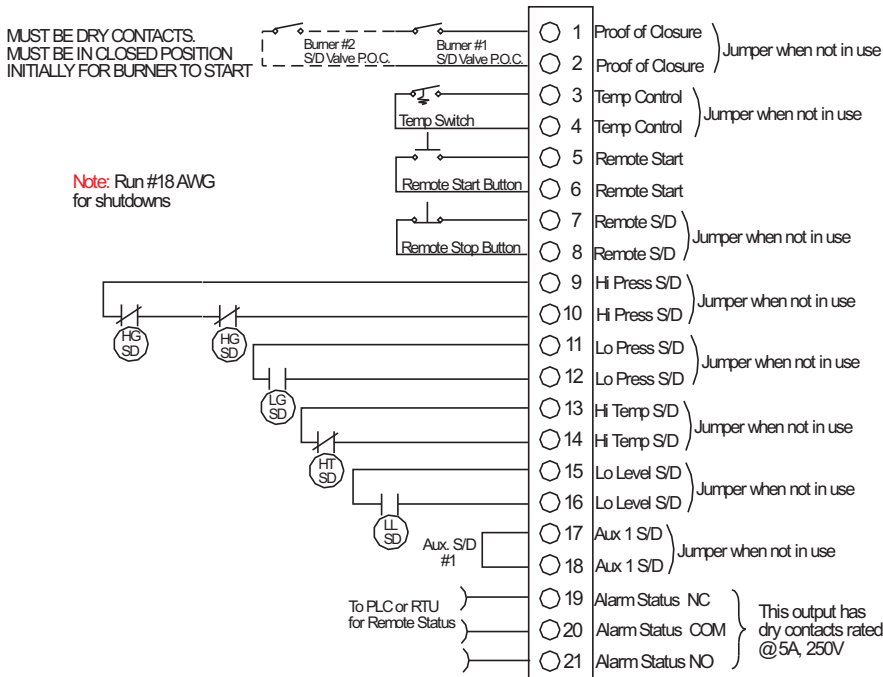

### BURNER #1

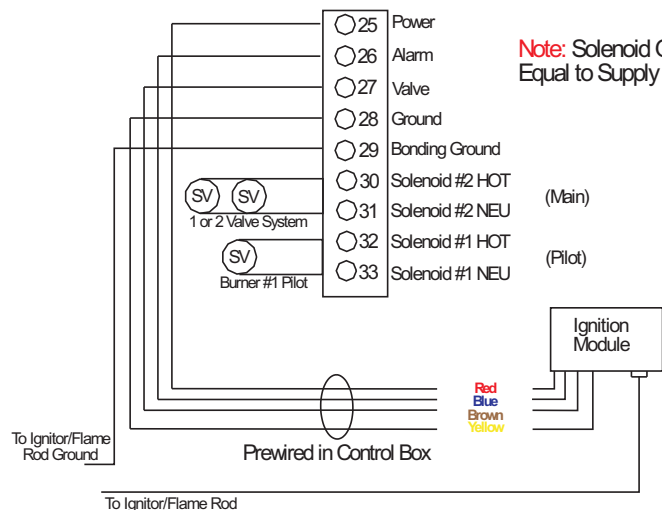

### BURNER #2

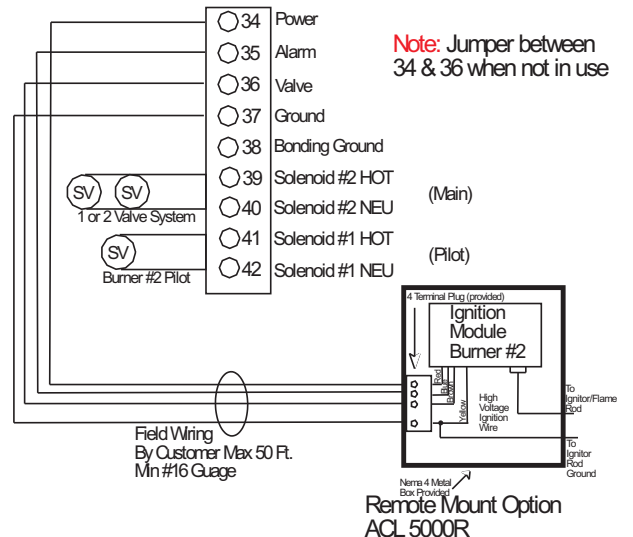

# ACL 5500 COMBUSTION SAFETY CONTROL

## Valve Train - Pneumatic Single Burner Configuration

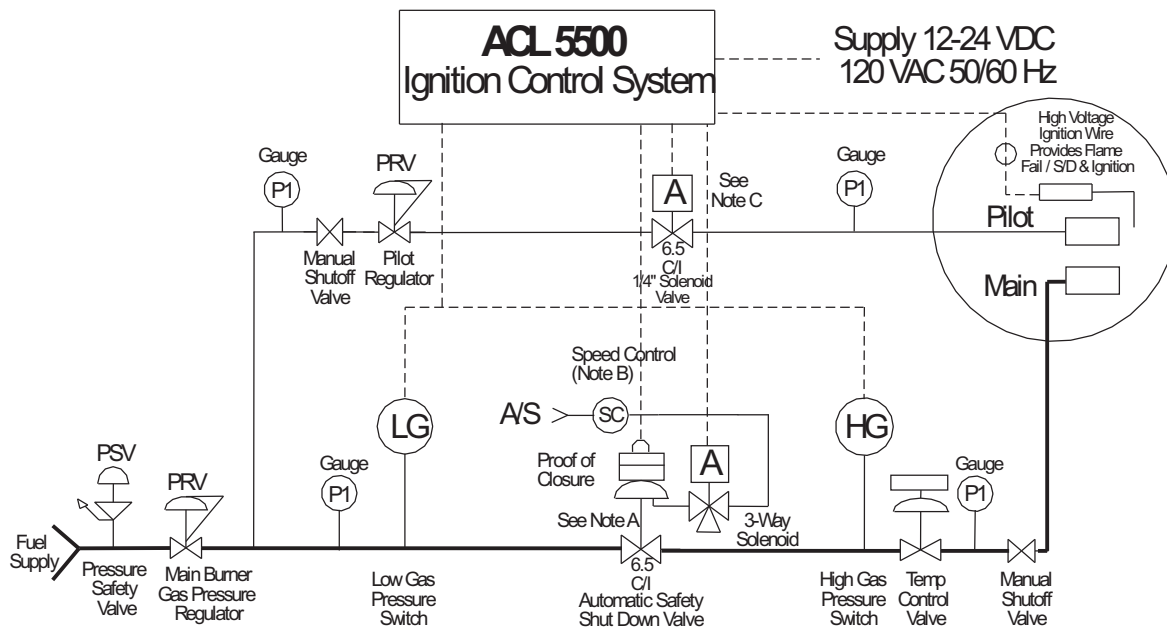

**This drawing is recommended for use with gas appliances that must conform to CSA B149.3 - 10.**

Note A: Auto safety shutdown valve with proof of closure switch- in accordance with CSA standard 6.5-2005/ANSI Z21.21 and marked C/I Class I Div 1.

Note C: CSA approved Class I, Div 1 solenoid valve- 6.5-2005/ANSI Z21.21 C/I 1/4" solenoid valve.

Note: If using separate fuel gas supply for Pilot, a Low Gas Pressure Switch is recommended in the pilot line.

# ACL 5500 SAFETY COMBUSTION CONTROL

## Valve Train - Electric Single Burner Configuration

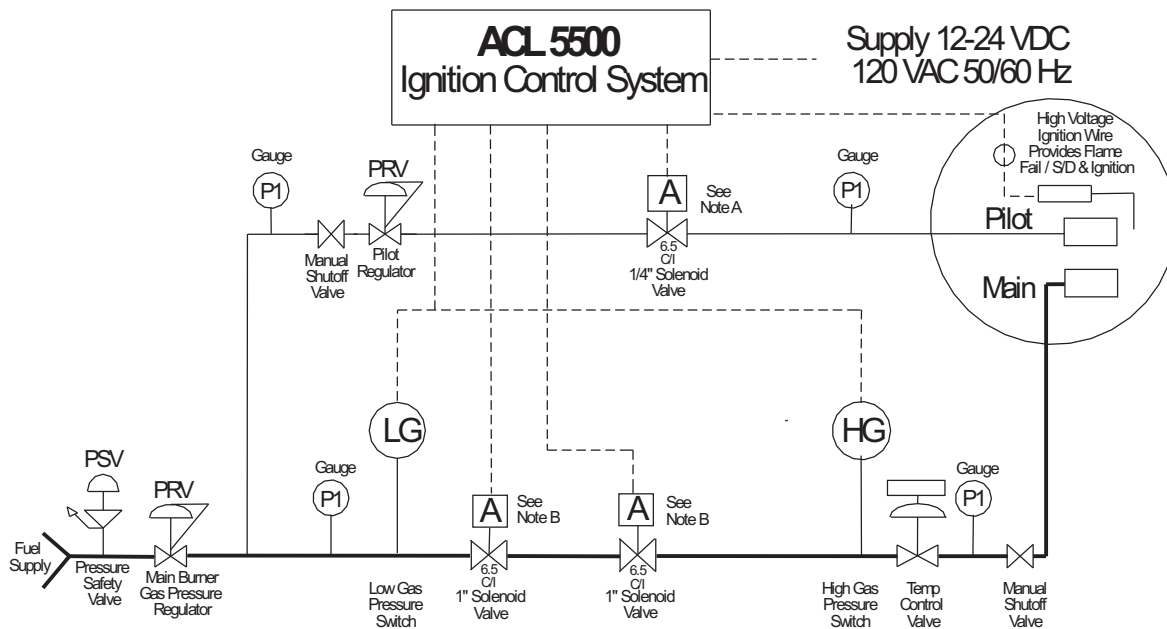

**This drawing is recommended for use with gas appliances that must conform to CSA B149.3 - 10.**

Note A: Solenoid CSA certified 6.5-2005 C/I Class I Div 1 1/4" solenoid valve.

Note B: Solenoid CSA certified 6.5-2005 C/I Class I Div 1 1" solenoid valve.

Note: If using separate fuel gas supply for Pilot, a Low Gas Pressure Switch is recommended in the pilot line.

# ACL 5500 COMBUSTION SAFETY CONTROL

## Valve Train - Pneumatic Dual Burner Configuration

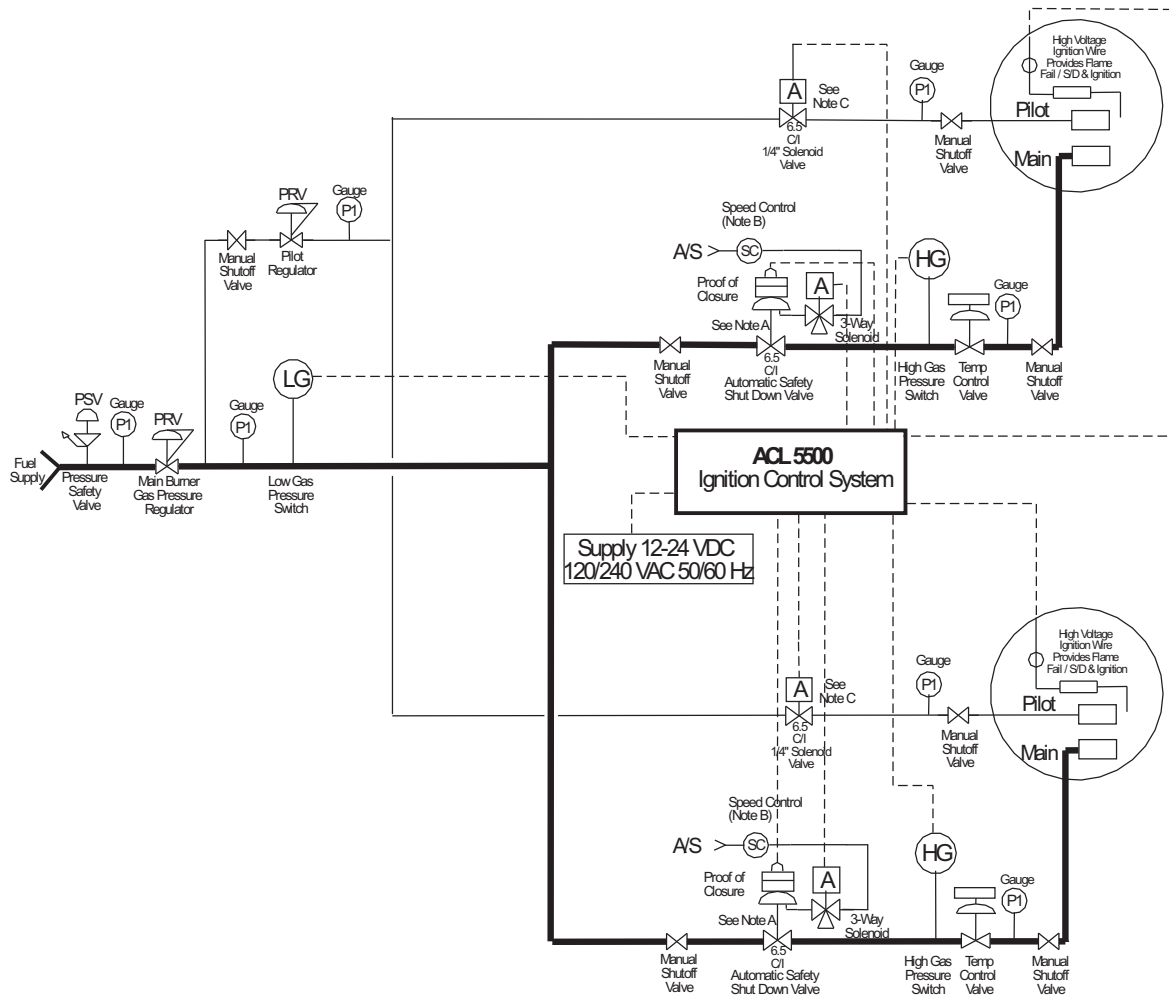

**This drawing is recommended for use with gas appliances that must conform to CSA B149.3 - 10**

Note A: Auto safety shutdown valve with proof of closure switch- in accordance with CSA Standard 6.5-2005/ANSI Z21.21 and marked C/I Class I Div 1.

Note C: CSA Standard 6.5-2005/ANSI Z21.21 and marked C/I solenoid valve- Class I Div 1 1/4\" solenoid valve

Note: If using separate fuel gas supply for Pilot, a Low Gas Pressure Switch is recommended for pilot line

## Valve Train - Electric Dual Burner Configuration

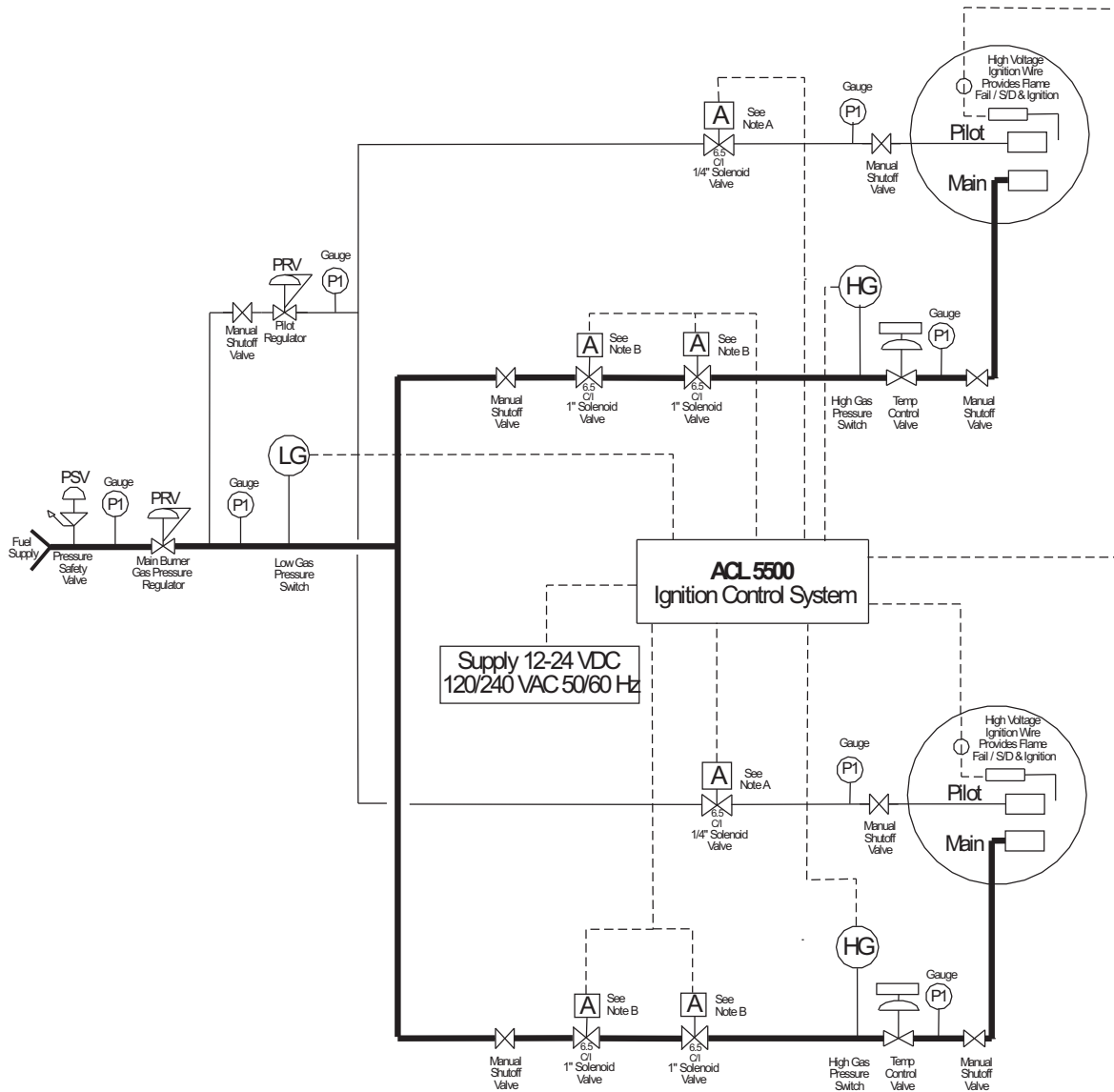

**This drawing is recommended for use with gas appliances that must conform to CSA B149.3 - 10**

Note A: Solenoid CSA Certified 6.5-2005 C/I Class I Div 1 1/4" solenoid valve or equivalent

Note B: Solenoid CSA Certified 6.5-2005 C/I Class I Div 1 1" solenoid valve or equivalent

Note: If using separate fuel gas supply for Pilot, a Low Gas Pressure Switch is recommended for pilot line

# ACL 5500 COMBUSTION SAFETY CONTROL

## Flame Signal Test Procedure

1. Turn power off to ACL controller
2. Remove High-Voltage Ignition wire from Ignition Module and insert meter leads with test harness as shown
3. Turn on power and initiate start sequence
4. Meter will give erratic readings during ignition period but should settle down between 1-2 $\mu$ A reading on meter
5. Adjust air shutter on pilot mixer and adjust pressure on regulator to achieve a flame signal close to 2 $\mu$ A which is optimum

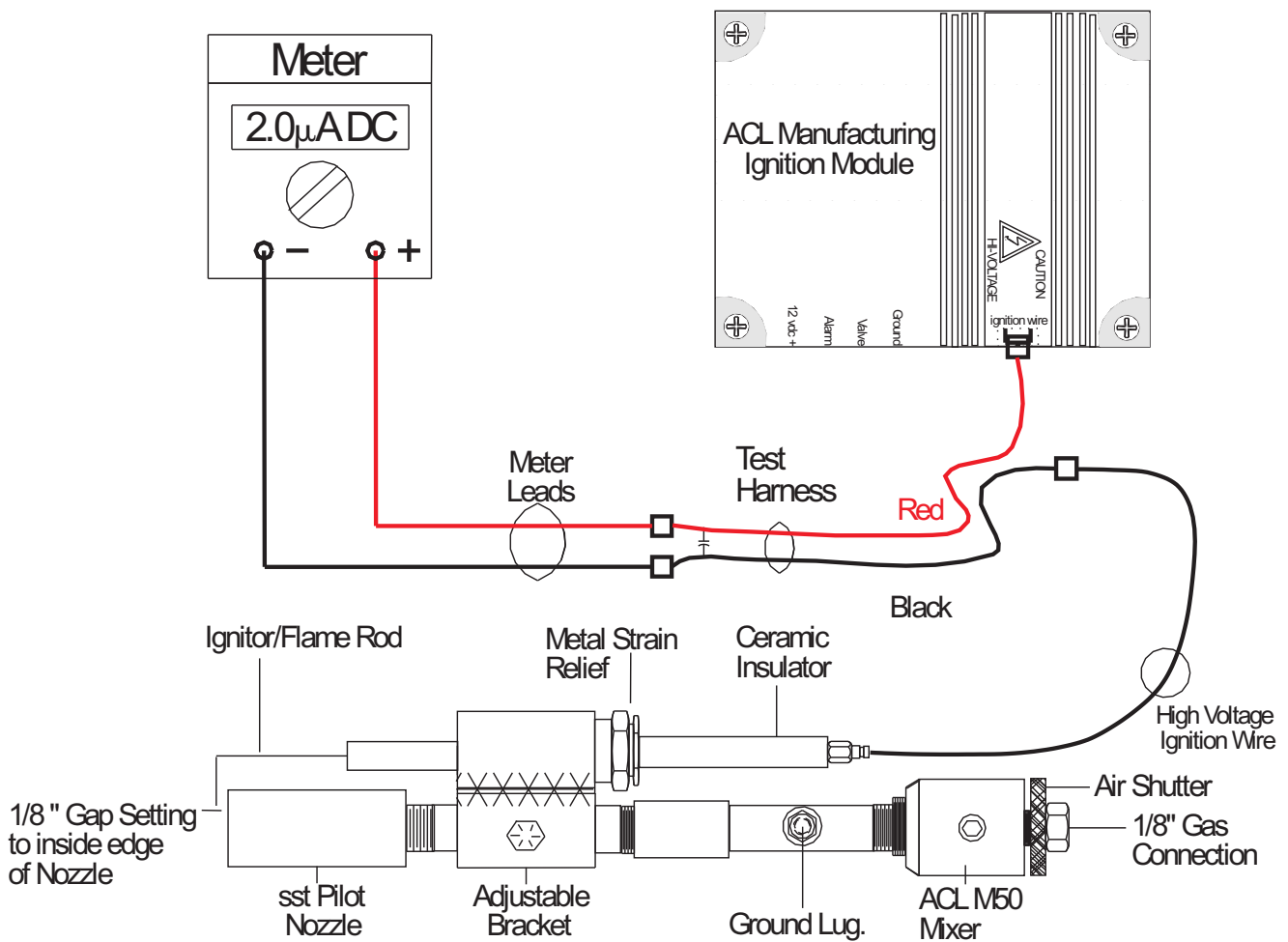

## ACL HE-ON BURNER

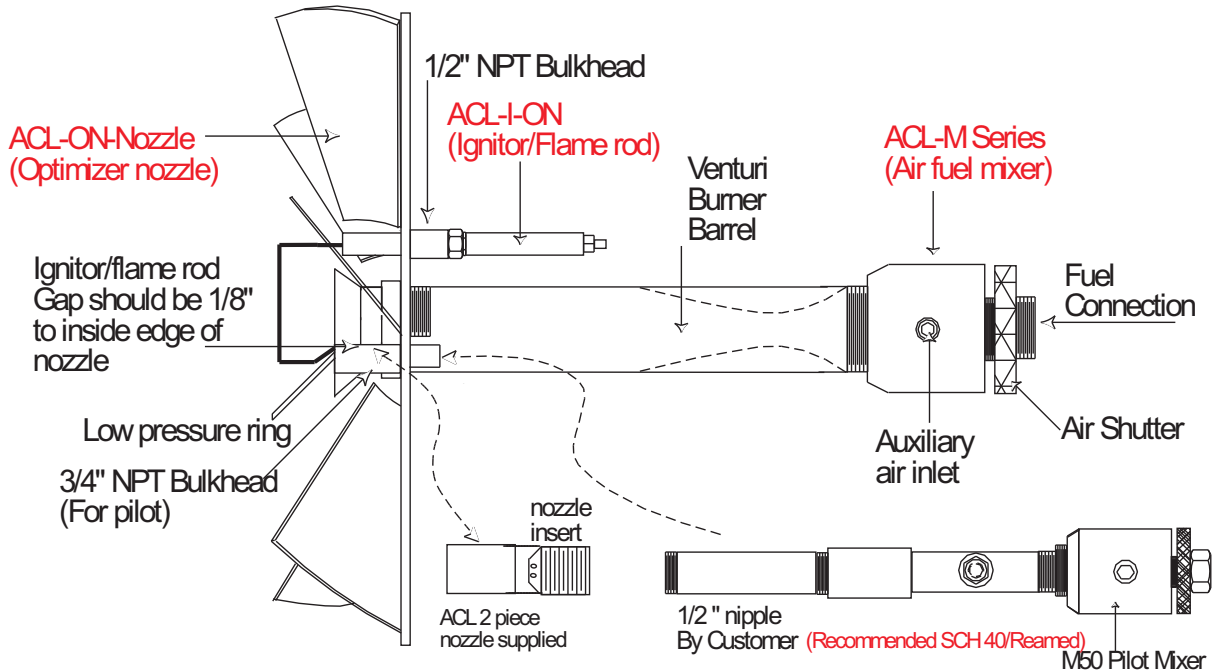

### Pilot Assembly

Note: This pilot assembly can be used as a stand alone unit using adjustable bracket or incorporated with our ACL-HE-ON Burner assembly as shown. Simply unscrew 3/4" bulkhead located on ACL-HE-ON Burner.

### ACL HE-ON Burner Front View

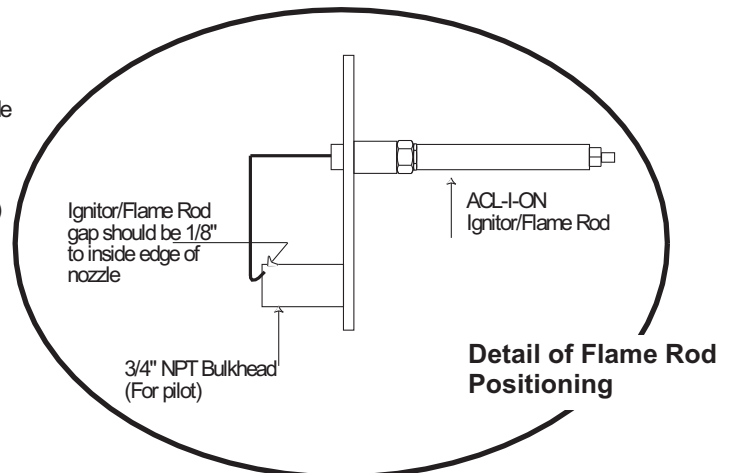
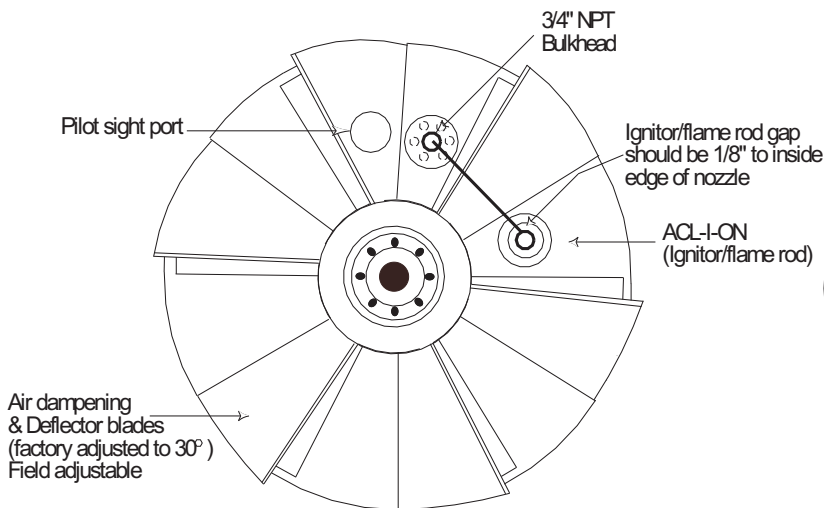

# ACL 5500 COMBUSTION SAFETY CONTROL

## PILOT ASSEMBLY

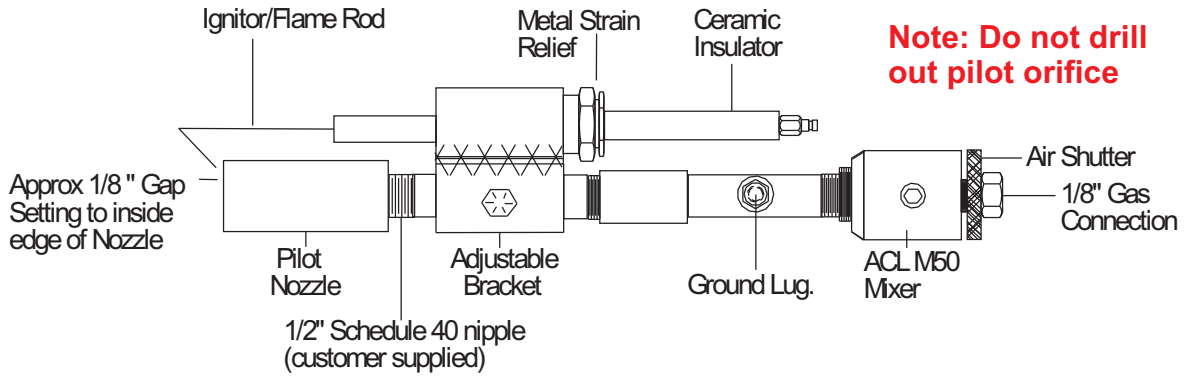

## OPTIONAL PILOT ASSEMBLY

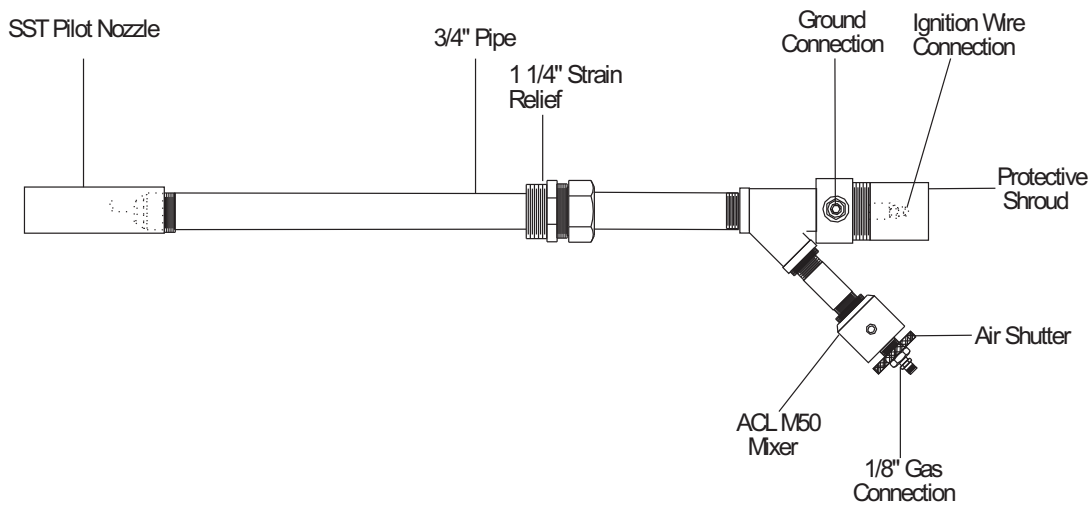

## Control Box Dimensions

### Outside Dimensions

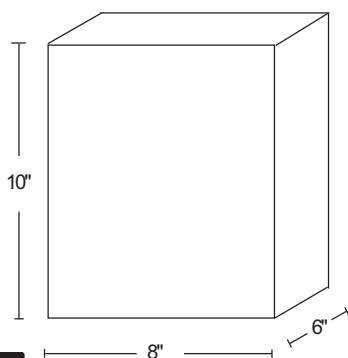

### Side View

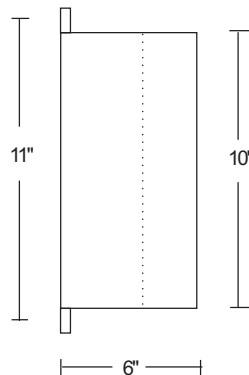

### Mounting Dimensions

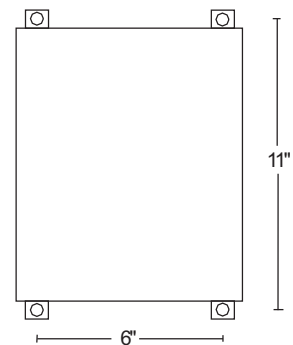





Website: [www.aclmfg.com](http://www.aclmfg.com)

## **Limited Warranty**

Seller warrants that the product hereby purchased is, upon delivery, free from defects in material and workmanship and that any product which is found to be defective in such workmanship or material will be repaired or replaced by Seller for a period of one year from purchase date. Warranty of such items do not include shipping, installation or set-up.

## **Liability Statement**

ACL Manufacturing Inc. Shall not be liable for any special, indirect, consequential or other damages of a like general nature, including, without limitation, loss of profits or production, or loss of expenses of any nature incurred by the buyer or any third party.

---

**805 Main Ave West - Box 2002 Sundre, Alberta T0M 1X0**  
**Phone: (403) 638-5234 - Fax: (403) 638-4973**  
**E-mail: [aclmfg@telus.net](mailto:aclmfg@telus.net)**