

**ACL**

**ACL 5100 COMBUSTION SAFETY CONTROL**

**Manufacturing Inc.**

# **INSTALLATION MANUAL**

## **FOR**

# **ACL 5100 COMBUSTION SAFETY CONTROLLER**



## **WARNING**

**This manual must be read in its entirety before installation of this controller. Installation must be performed by a qualified technician and must adhere to the standards set by the local regulatory authorities.**

**ACL is not responsible for the misuse or incorrect application of this product.**

# ACL 5100 COMBUSTION SAFETY CONTROL



## ACL 5100 PROVIDES

- SINGLE & THREE TRIALS FOR IGNITION
- FLAME MONITORING
- INDICATION OF PILOT ON & SYSTEM ON
- ALARM INDICATION OF FLAME FAIL, POWER FAIL, & SHUTDOWN
- REMOTE STOP AND START CAPABILITIES
- PRE-PROGRAMMED LOGIC  
(NO PROGRAMMING NECESSARY)
- Power supply 12/24 VDC, 120/240 VAC 50/60 Hz, low power consumption, suitable for solar applications
- Flame out response time of 0.8 seconds
- CSA approved for Class I, Div 2 location
- CSA approved C22.2 No 199-M89. Combustion safety controls and solid-state Ignitors for Gas & Oil burning Equipment
- CSA B149.3 - 10 compatible
- Type 4x enclosure, corrosive resistant and weatherproof



# ACL 5100 COMBUSTION SAFETY CONTROL

**APPLICATION** The ACL 5100 combustion safety controller is designed to ignite and prove a continuous pilot while monitoring and annunciating multiple heater shutdowns for all types of gas fired heaters and industrial sized burner applications.

**THEORY OF OPERATION** The ACL 5100 utilizes a single ignitor/flame rod to provide both flame acknowledgment and ignition at the pilot tip. When the ACL 5100 starts its ignition sequence, fuel gas travels to the pilot tip where the ignitor/flame rod is located and sparking. Once the gas is lit, the flame becomes a current path for flame acknowledgment and the unit stops sparking. After the pilot has been proven for 20 seconds (factory set) the ACL 5100 will allow gas to the main burner.

If the pilot flame is extinguished, the current path is broken and the ignitor/flame rod starts sparking within 1 second to attempt to re-light the pilot. The main is shut off during this re-light period. If a flame is not established within the 5 second sparking period, the controller will immediately drop the output to solenoid #1 pilot gas valve. The controller will attempt to light 2 more times with 15 seconds between each trial when equipped with three trial ignition module. If the flame is still not lit, the flame fail alarm will be indicated by a continuous alarm light.

If any of the shutdowns are tripped, the controller will not attempt any re-light, and solenoid outputs will de-energize immediately. A shutdown will then be indicated by the flashing alarm light. The shutdown must be cleared before the controller will allow an ignition cycle.

The controller also has a power fail indicator to determine brownouts or power disconnection and this is indicated by a flashing system on light after power has been restored.

# ACL 5100 SAFETY COMBUSTION CONTROL

## INSTALLATION

- ACL 5100 controller c/w mounting hardware
- ACL M-50A pilot mixer & nozzle
- 10' ground wire
- 10' high voltage wire complete with connectors
- 6.5' non-metallic flex complete with connectors
- Ignitor/flame rod complete with mounting hardware
- Speed control valve
- 1/2" conduit seal
- Flame current test leads
- Operator's manual

**ACL 5100 COMES COMPLETE WITH**

The ACL 5100 can be mounted in a Class I, Div 2 area; usually close to the burner. The 10' of high voltage lead, (longer lengths are not recommended) must be run in the non-metallic flex (provided) or free air. If the high voltage lead is run in the non-metallic flex, a conduit seal (provided) must be installed. Note: Lead lengths in excess of 10' or use of metal or metallic sheathed conduit may result in a diminished ignitor rod voltage. A ground wire (also supplied) must be connected between the ground lug on the burner assembly and the bonding ground terminal on the main circuit board. **Note: If the controller must be mounted farther away from the burner assembly, the ignition module, which is mounted on the main circuit board, may be mounted in or near the burner housing using the optional, CSA approved, ACL 5000R remote mount kit. Do not coil excess high voltage lead inside controller enclosure. High voltage magnetic field may damage sensitive components. Electronic components and cables in close proximity to the ignition module and ignition cable may be affected by high voltage noise.**

### MOUNTING

The ACL 5100 is available in 12/24 VDC and 120/240 VAC. Voltage requirements must be specified when ordering. The supply voltage of each unit is clearly marked inside the door on the specification label and on the circuit board beside its respective terminal. **Incorrect polarity on 12/24 VDC units may result in damage to circuit board components.** The terminal marked ground is for supply or system ground and the terminal marked bonding ground is strictly for the ground wire to the burner assembly. It is important that a ground wire (supplied) be connected between the bonding ground terminal and the burner assembly to provide an uninterrupted path for the flame acknowledgment current.

### POWER CONNECTION

There are two solenoid output terminals on the main circuit board marked pilot solenoid and main solenoid. The output voltage at these terminals is always the same as the controller supply voltage. The pilot solenoid output connects to the pilot or low fire solenoid and is energized when a start is initiated. Main solenoid, (main burner) energizes only after the pilot or low fire flame has been proven. The time delay between proof of flame and energizing of main output is factory set at 20 seconds. Available in all three voltages).

### SOLENOID OUTPUTS

# ACL 5100 COMBUSTION SAFETY CONTROL

## S/D INPUTS

The shutdown input provides a means of connecting other shutdown devices such as low level, high temperature, low gas and high gas shutdowns for additional protection. A jumper is installed at the factory and should only be removed to utilize this feature. Shutdown devices connected (in series) to the shutdown terminal, **must be dry contacts** and be in a closed state during normal operating conditions. If any of the S/D switches go to fault condition, their contacts will open, de-energizing the solenoid outputs and shutting down fuel to the pilot and main burners and disabling the re-light sequence. This will be indicated by the alarm light flashing. Once the fault condition is corrected the system can be restarted by pressing the stop/reset and then the start buttons. **Note: if a restart is attempted without clearing the fault condition, the controller will not attempt a re-light. Do not run shutdown loop wire in the same conduit as solenoid wiring. Induced voltage may damage sensitive circuit board components.**

## REMOTE S/D (STOP)

The remote S/D function is available when the jumper is removed and a momentary normally closed contact button or remote relay contact (N/C) is utilized. **Note: Must be dry contacts.**

## REMOTE START

The remote start function is available when a momentary normally open contact button or remote relay contact (N/O) is utilized. When contacts close momentarily the unit initiates starting sequence. **Note: Must be dry contacts.**

## PROOF OF CLOSURE (P.O.C)

This feature allows controller to use valves with proof of closure switches for ensuring main valve is closed before initiating an ignition. When valve switch contacts are in an open state indicating the valve may be open, the controller will not start. The contacts must be closed in order for controller to start. Once start is initiated, the contacts from proof of closure switch can then change state.

## SYSTEM ON LIGHT

The system on light indicates power supplied to the ACL 5100. When it is flashing it indicates there has been a power failure.

## ALARM LIGHT

A solid light indicates the pilot has failed to ignite. A flashing light indicates a shutdown is open.

## ALARM STATUS

Alarm status is provided from a set of normally open/normally closed **dry contacts** which change state when a pilot flame is detected. If the pilot goes out due to any of the shutdowns or fails to re-light, the contacts return to normal or alarm state.

# ACL 5100 SAFETY COMBUSTION CONTROL

<b>SPECIFICATIONS DC</b>	
	ONE BURNER
VOLTAGE	12 VDC    24VDC
CURRENT	0.204A    0.186A
POWER	2.4W    4.5W
SOLENOID OUTPUT RATINGS	5 amp 250 V Per Output
OPERATING TEMPERATURE	-40 C to 60 C
FLAME SENSITIVITY	1 micro amp minimum
FLAME FAILURE RESPONSE TIME	0.8 seconds maximum
SPARK RATE	25 sparks per second

<b>SPECIFICATIONS AC</b>	
	ONE BURNER
VOLTAGE	120 VAC    240 VAC
CURRENT	0.282A
POWER	33.84W
FREQUENCY	50/60 HERTZ
SOLENOID OUTPUT RATINGS	5 amp 250 V Per Output
OPERATING TEMPERATURE	-40 C to 60 C
FLAME SENSITIVITY	1 micro amp minimum
FLAME FAILURE RESPONSE TIME	0.8 seconds maximum
SPARK RATE	25 sparks per second

# ACL 5100 COMBUSTION SAFETY CONTROL

## ACL 5100 12/24 VDC

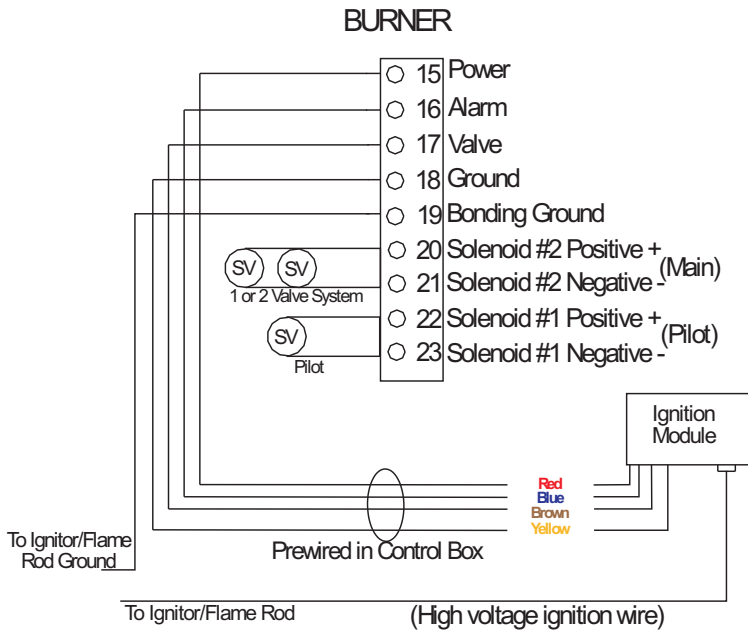
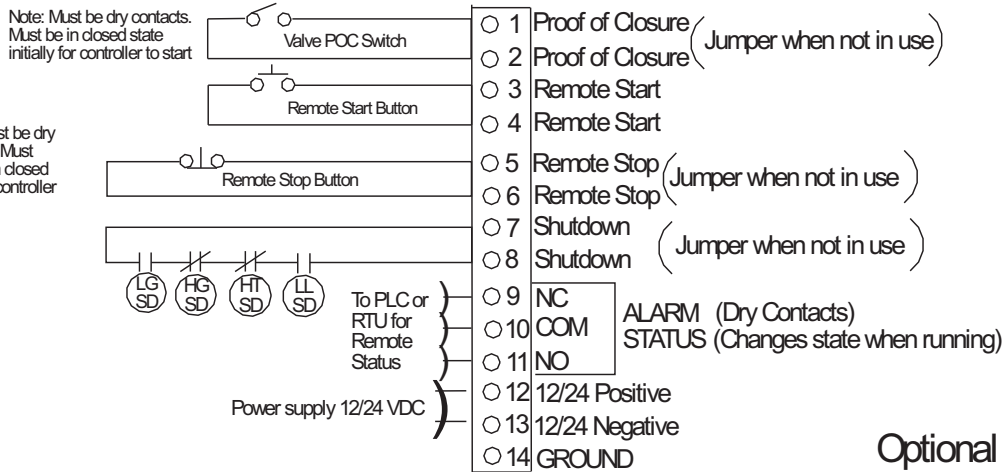

### Optional Remote Mount Ignition Module

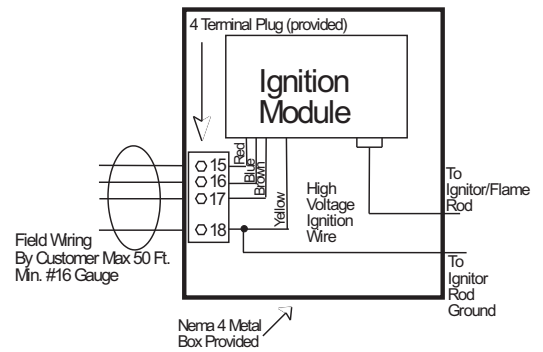

**NOTE:** If remote mounting of ignition module is preferred, the ACL 5000R remote mount kit is available upon request.

# ACL 5100 SAFETY COMBUSTION CONTROL

## ACL 5100 120/240 VAC

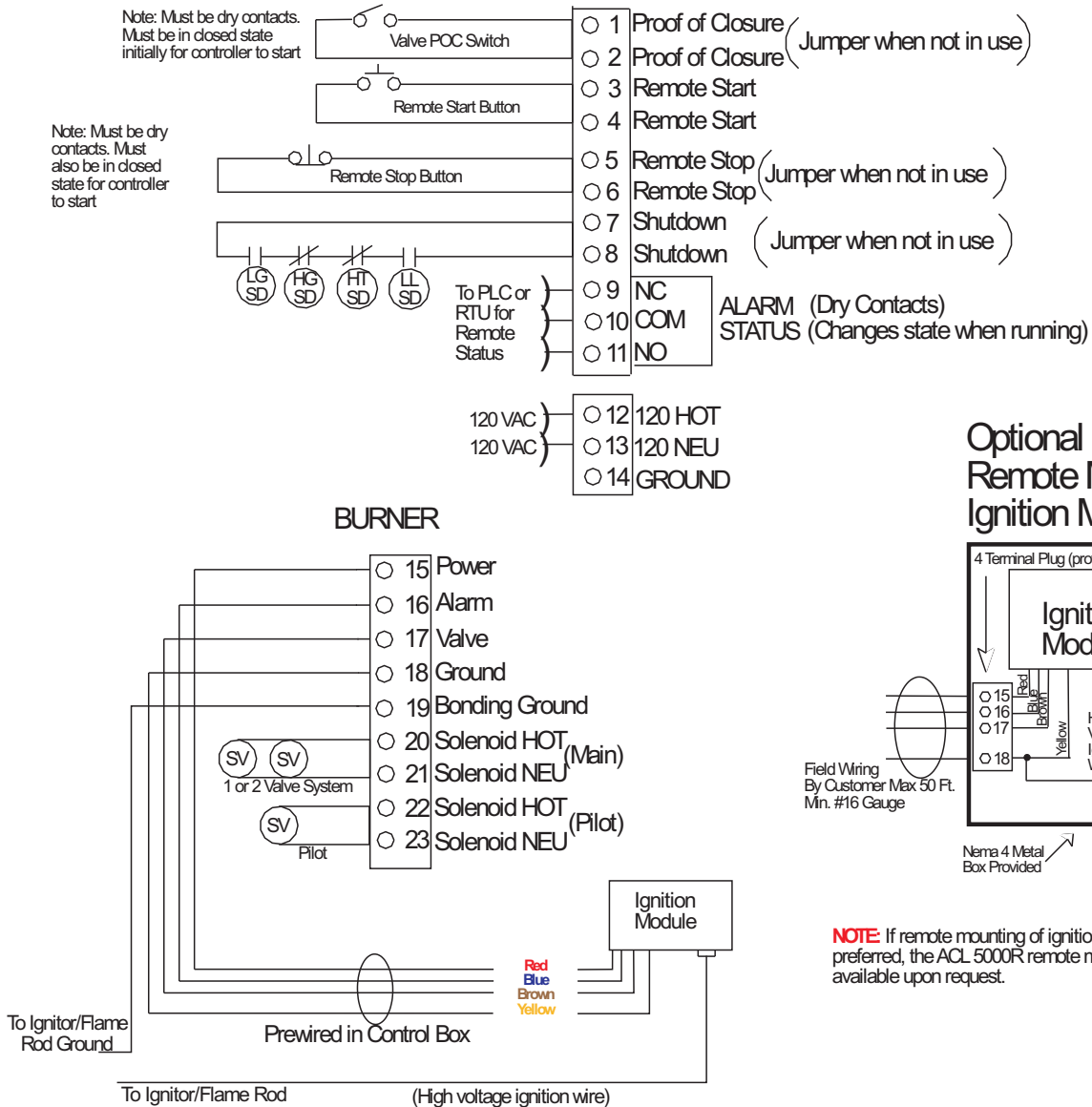

### Optional Remote Mount Ignition Module

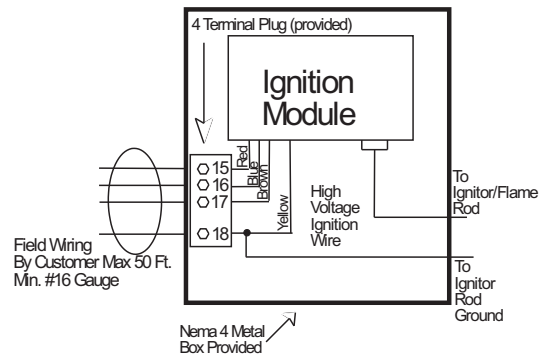

**NOTE:** If remote mounting of ignition module is preferred, the ACL 5000R remote mount kit is available upon request.

# ACL 5100 COMBUSTION SAFETY CONTROL

## Valve Train - Pneumatic Proof of Closure Valve

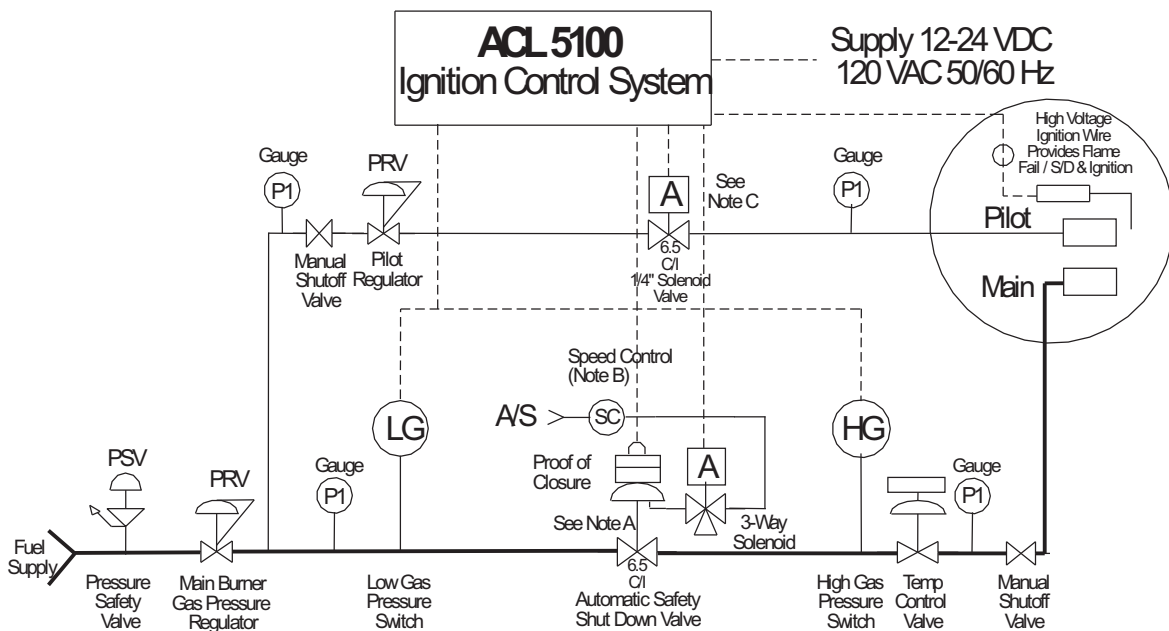

**This drawing is recommended for use with gas appliances that must conform to CSA B149.3 - 10.**

Note A: Auto safety shutdown valve with proof of closure switch- in accordance with CSA standard 6.5-2005/ANSI Z21.21 and marked C/I Class I Div 1.

Note B: 1/4" x 1/4" Speed Control Valve supplied.

Note C: CSA standard 6.5-2005 C/I Class I Div 1 1/4" solenoid valve.

Note: If using separate fuel gas supply for Pilot, a Low Gas Pressure Switch is recommended in the pilot line.

# ACL 5100 SAFETY COMBUSTION CONTROL

## Valve Train - Electric Solenoid Valves

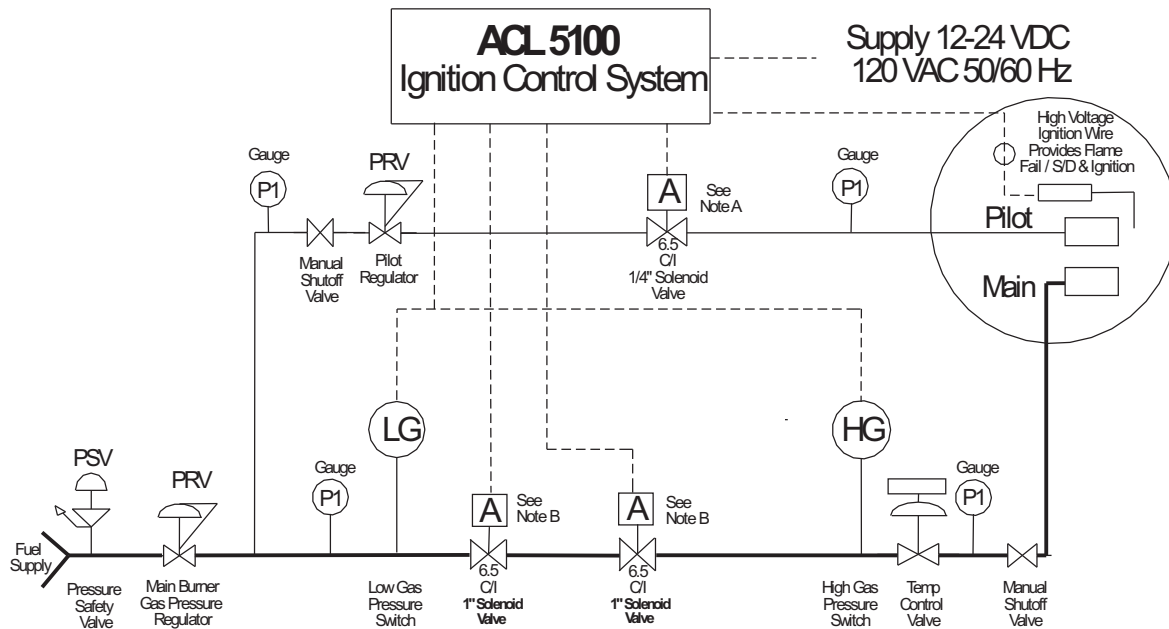

**This drawing is recommended for use with gas appliances that must conform to CSA B149.3 - 10.**

Note A: Solenoid CSA certified 6.5-2005 C/I Class I Div 1 1/4" solenoid valve or equivalent.

Note B: Solenoid CSA certified 6.5-2005 C/I Class I Div 1 1" solenoid valve or equivalent.

Note: If using separate fuel gas supply for Pilot, a Low Gas Pressure Switch is recommended in the pilot line.

# ACL 5100 COMBUSTION SAFETY CONTROL

## Flame Signal Test Procedure

1. Turn power off to ACL controller
2. Remove High-Voltage Ignition wire from Ignition Module and insert meter leads with test harness as shown
3. Turn on power and initiate start sequence
4. Meter will give erratic readings during ignition period but should settle down between 1-2 $\mu$ A reading on meter
5. Adjust air shutter on pilot mixer and adjust pressure on regulator to achieve a flame signal close to 2 $\mu$ A or greater which is optimum

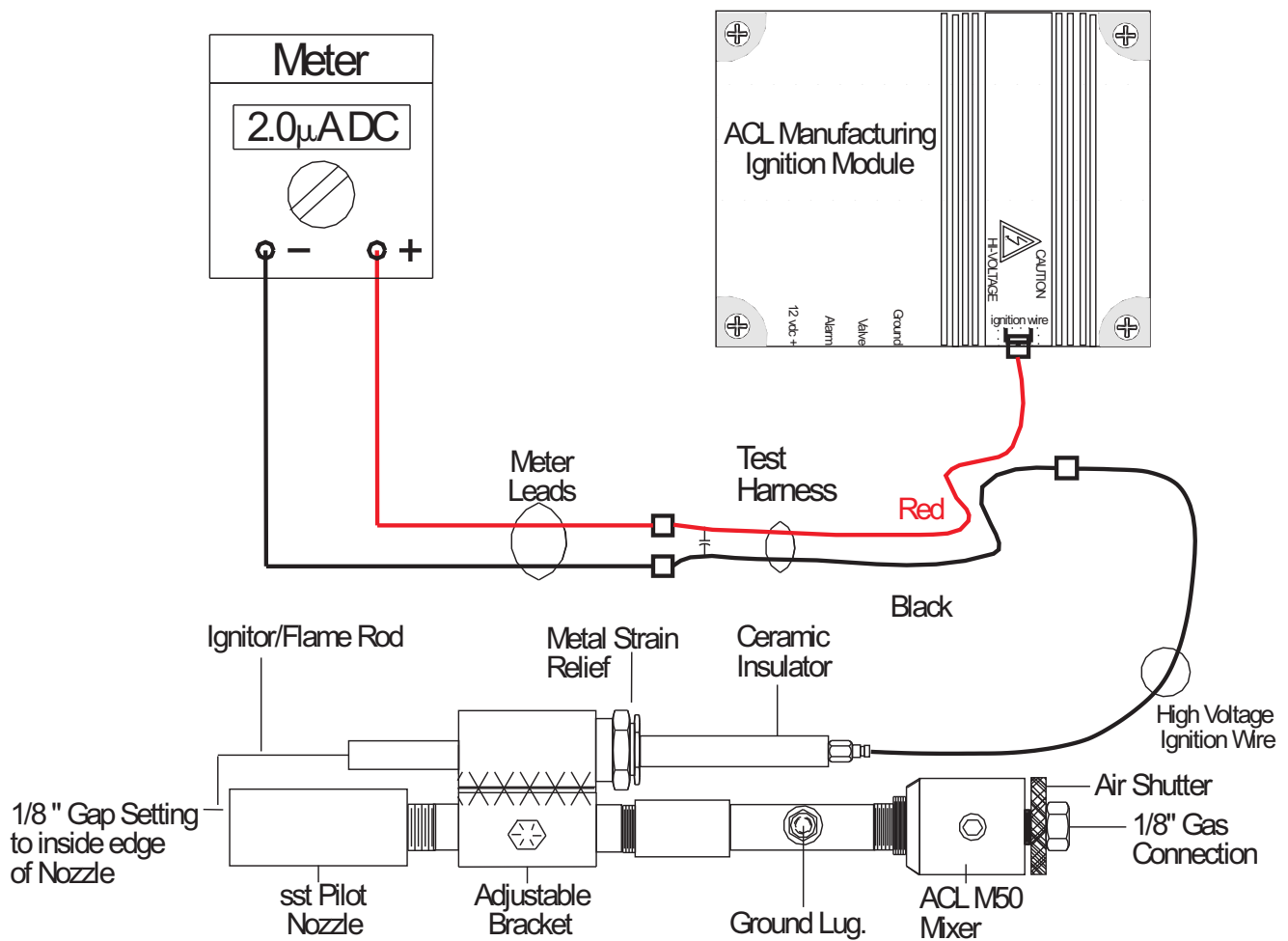

# ACL 5100 SAFETY COMBUSTION CONTROL

## ACL HE-ON BURNER

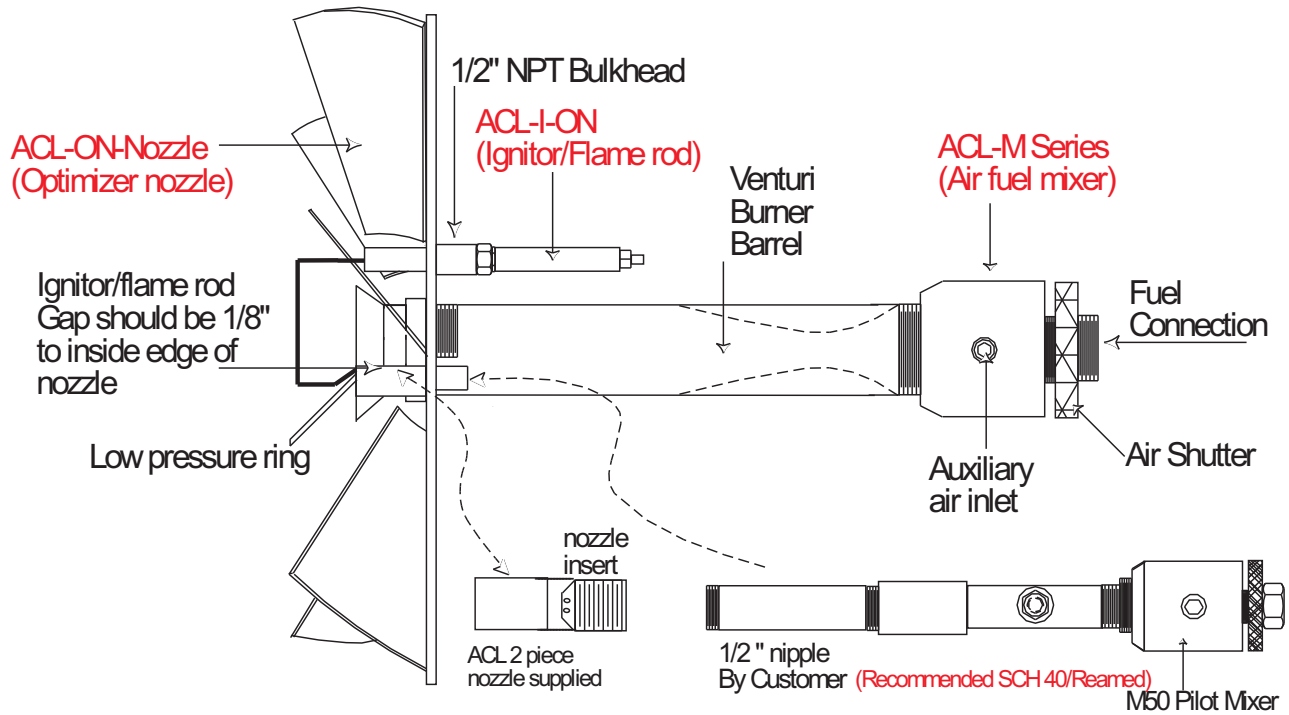

### Pilot Assembly

Note: This pilot assembly can be used as a stand alone unit using adjustable bracket or incorporated with our ACL-HE-ON Burner assembly as shown. Simply unscrew 3/4" bulkhead located on ACL-HE-ON Burner.

### ACL HE-ON Burner Front View

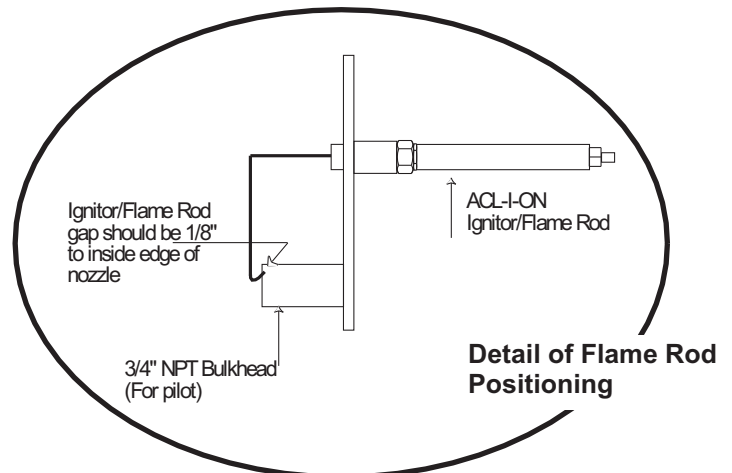
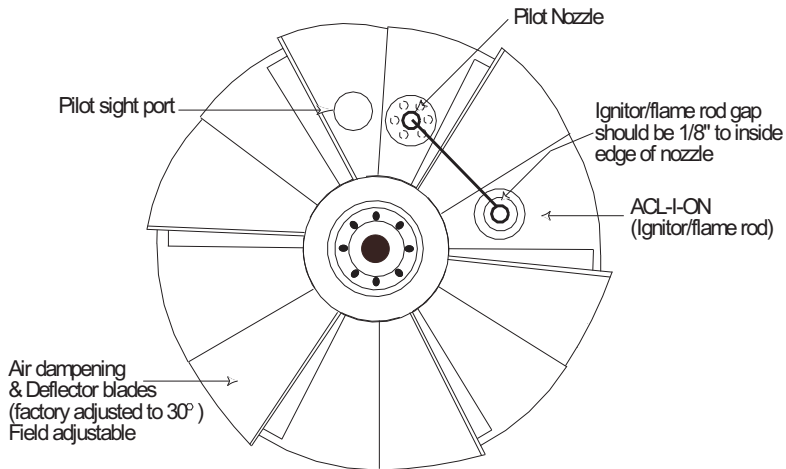

# ACL 5100 COMBUSTION SAFETY CONTROL

## PILOT ASSEMBLY

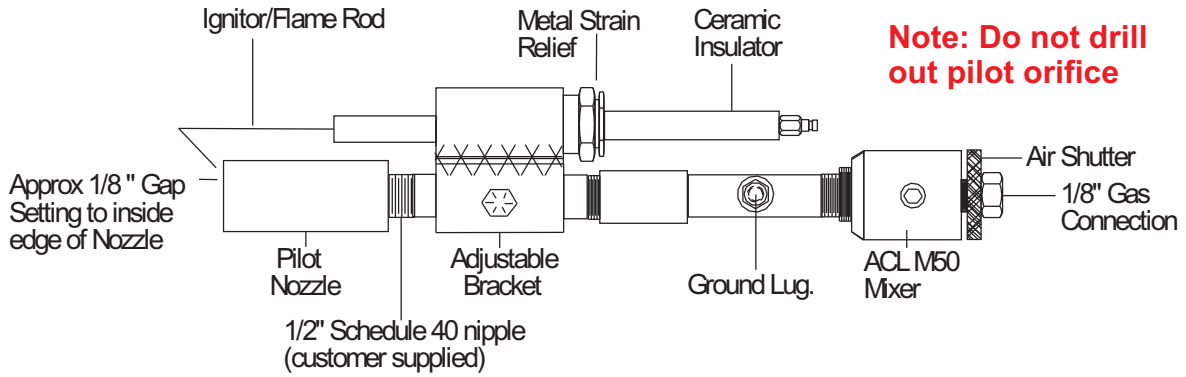

## OPTIONAL PILOT ASSEMBLY (ACL 1500)

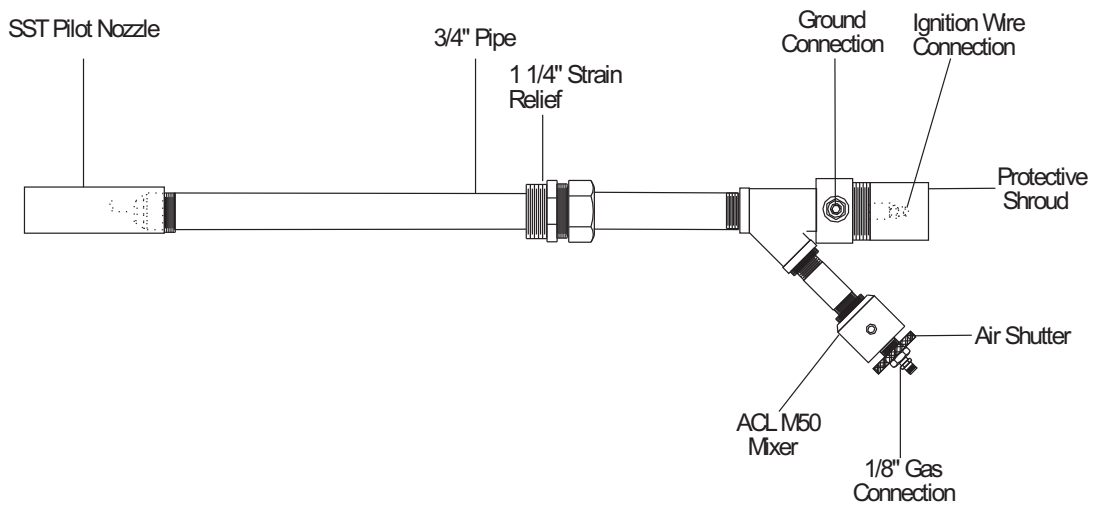

## Control Box Dimensions

### Outside Dimensions

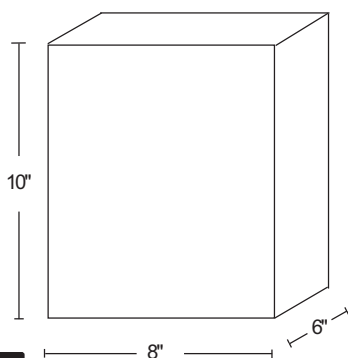

### Side View

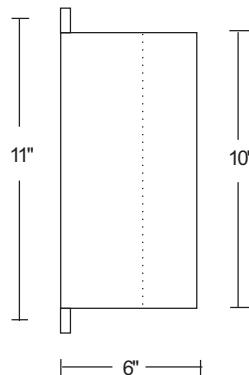

### Mounting Dimensions

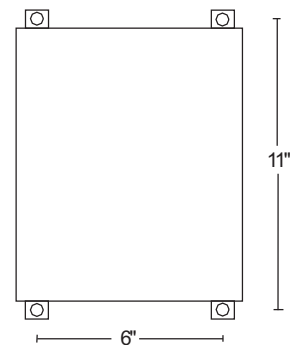





Website: [www.aclmfg.com](http://www.aclmfg.com)

## **Limited Warranty**

Seller warrants that the product hereby purchased is, upon delivery, free from defects in material and workmanship and that any product which is found to be defective in such workmanship or material will be repaired or replaced by Seller for a period of one year from purchase date. Warranty of such items do not include shipping, installation or set-up.

## **Liability Statement**

ACL Manufacturing Inc. Shall not be liable for any special, indirect, consequential or other damages of a like general nature, including, without limitation, loss of profits or production, or loss of expenses of any nature incurred by the buyer or any third party.

---

**805 Main Ave West - Box 2002 Sundre, Alberta T0M 1X0**  
**Phone: (403) 638-5234 - Fax: (403) 638-4973**  
**E-mail: [aclmfg@telus.net](mailto:aclmfg@telus.net)**